



**MAGTROL**

**TENSION – TORQUE**



**Highly Reliable Hysteresis Devices  
for Tension and Torque Control**

- ▶ **Hysteresis Brakes**
- ▶ **Hysteresis Clutches**
- ▶ **Large Bore Brakes**
- ▶ **Matched Brakes**
- ▶ **Compressed-air-cooled Brakes**
- ▶ **Permanent Magnet Brakes/Clutches**

# PRINCIPLES OF HYSTERESIS

## Overview

The hysteresis effect in magnetism is applied to torque control by the use of two basic components—a reticulated pole structure and a specialty steel rotor/shaft assembly—fastened together but not in physical contact. Until the field coil is energized, the drag cup and shaft can spin freely on its bearings.

When a magnetizing force from either a field coil or magnet is applied to the pole structure, the air gap becomes a flux field. The rotor is magnetically restrained, providing a braking action between the pole structure and rotor.

Because torque is produced strictly through a magnetic air gap, without the use of friction or shear forces, Magtrol Hysteresis Brakes provide absolutely smooth, infinitely controllable torque loads, independent of speed, and they operate quietly without any physical contact of interactive members. As a result, with the exception of shaft bearings, no wear components exist.

## Advantages

- Long, Maintenance-Free Life
- Life Cycle Cost Advantages
- Operational Smoothness
- Superior Torque Repeatability
- Broad Speed Range
- Excellent Environmental Stability

## Control

In an electrically operated Hysteresis Brake, adjustment and control of torque is provided by a field coil. This allows for complete control of torque by adjusting DC current to the field coil. Adjustability from a minimum value (bearing drag) to a maximum value of rated torque is possible. Additional torque in the range of 15 to 25% above rated torque may be available on some brakes.

The amount of braking torque transmitted by the brake is proportional to the amount of current flowing through the field coil. The direction of current flow (polarity) is of no consequence to the operation of the brake. For optimum torque stability, a DC supply with current regulation is recommended. This will help to minimize torque drift attributable to changes in coil temperature and in-line voltage, which can result in changes in coil current, and consequently, in torque.

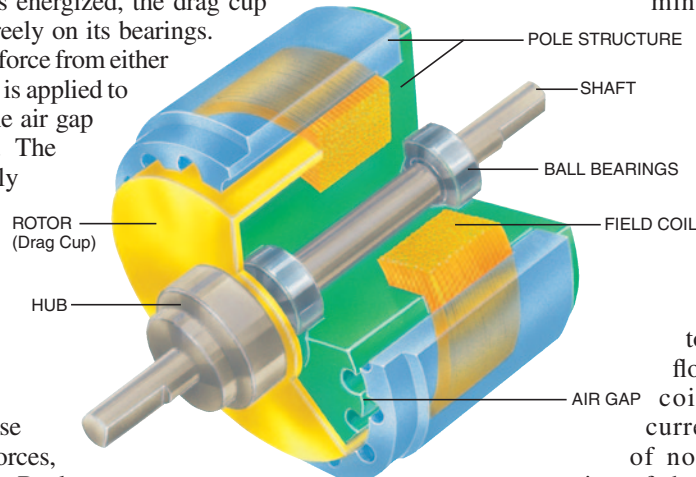

# APPLICATIONS

## Hysteresis Brakes

- Precise control of wire tension during wind, hook and cut operation of high-speed automated winding machines
- Frictionless, non-breakaway force for tensioning materials during slitting and many other material processing operations
- Load simulation applications for life testing on electric motors, actuators, small gas engines, gearboxes, and many other rotating devices and assemblies
- Open loop control for maintaining precise tension during winding process in transformer and coil winding operations
- Holding of backdriving loads
- Ultimate tension control, regardless of control scheme—dancer roll, follower arm, photo or ultrasonic sensors
- Precise load control and programmed repeatability in high-end exercise equipment

## Matched Brakes

- Tension control applications that have multiple webs or strands
- Multiple pay-off systems where one sensor controls tension in the system

## Large Bore Brakes

- Helical wrapping, braiding and other feed-through applications—used in machines for manufacturing cable, wire, fiber optic cable, rope and tape
- Flyer control in winding operations

## Hysteresis Clutches

- Precise control of torque for capping, bolting and other screw applications
- Torque limiting in order to prevent over torque and provide precise, stable and smooth application of torque
- Closed-loop winding tension and speed control

# HYSSTERESIS BRAKES

## STANDARD BRAKES

Pure Hysteresis Brakes produce torque strictly through a magnetic air gap without the use of magnetic particles or friction components. This method of braking provides far superior operating characteristics (smoother torque, longer life, superior repeatability, high degree of controllability, and less maintenance and down time) which make them the preferred choice for precise tension control during the processing of nearly any material, web or strand.



ENGLISH BRAKE RATINGS										
Model	Min. Torque at Rated Current oz-in	Rated Current mA	Resistance at 25 °C ±10% Ω	Voltage* VDC	Nominal Power W	Max. Speed rpm	Kinetic Power**		Drag Torque De-energized @1000 rpm oz-in	
							5 Minutes W	Continuous W		
HB-2.5-2	2.5	146	171	25.0	3.7	20,000	20	5	0.05	
HB-8-2	8	133	180	24.0	3.2	20,000	60	15	0.10	
HB-16-2	16	192	125	24.0	4.6	20,000	75	20	0.10	
HB-32-2	32	250	105	26.3	6.6	15,000	90	25	0.20	
HB-50-2	50	253	95	24.0	6.1	15,000	90	23	0.20	
HB-140-2	140	253	95	24.0	6.1	12,000	300	75	0.70	
HB-250-2	250	270	96	25.9	7.0	10,000	450	110	1.00	
HB-450-2	450	442	50	22.1	9.8	8,000	670	160	2.00	
HB-750-2	750	383	60	23.0	8.8	7,000	1,000	200	7.00	
HB-840-2	840	600	40	24.0	14.4	6,000	1,340	300	4.00	
HB-1750-2	1750	500	52	26.0	13.0	6,000	1,200	350	13.00	
HB-3500-2	3500	1000	26	26.0	26.0	6,000	2,400	600	19.20	

METRIC BRAKE RATINGS										
Model	Min. Torque at Rated Current N-m	Rated Current mA	Resistance at 25 °C ±10% Ω	Voltage* VDC	Nominal Power W	Max. Speed rpm	Kinetic Power**		Drag Torque De-energized @1000 rpm N-m	
							5 Minutes W	Continuous W		
HB-3M-2	0.02	145	171	25.0	3.59	20,000	20	5	$3.53 \times 10^{-4}$	
HB-10M-2	0.07	133	180	24.0	3.18	20,000	35	8	$7.06 \times 10^{-4}$	
HB-20M-2	0.14	217	120	26.0	5.60	20,000	50	12	$7.77 \times 10^{-4}$	
HB-50M-2	0.35	253	95	24.0	6.10	15,000	90	23	$1.55 \times 10^{-3}$	
HB-140M-2	1.00	253	95	24.0	6.10	12,000	300	75	$5.42 \times 10^{-3}$	
HB-250M-2	1.75	270	96	25.9	7.00	10,000	450	110	$7.77 \times 10^{-3}$	
HB-450M-2	3.20	442	50	22.1	9.80	8,000	670	160	$1.51 \times 10^{-2}$	
HB-750M-2	5.00	383	60	23.0	8.80	7,000	1,000	200	$5.00 \times 10^{-2}$	
HB-1750M-2	† 13.00	600	52	31.2	13.00	6,000	1,200	350	$9.18 \times 10^{-2}$	
HB-3500M-2	†† 26.00	1200	26	31.2	26.00	6,000	2,400	600	$1.36 \times 10^{-1}$	

\* 12 VDC, 90 VDC and non-standard coil voltages are available on most models.

\*\* Kinetic power ratings are maximum values based on limiting coil and/or bearing temperature to approximately 100 °C, and should not be exceeded. Actual values in service may vary ±50% depending on mounting, ventilation, ambient temperature, etc.

† 13 N-m is attainable @ approx. 600 mA. This value may decrease to 12.36 N-m if the brake is powered by any power supply or controller limited to 500 mA.

†† 26 N-m is attainable @ approx. 1200 mA. This value may decrease to 24.72 N-m if the brake is powered by any power supply or controller limited to 1000 mA.

## COMPRESSED-AIR-COOLED BRAKES

When torque control/torque measurement must be performed at the highest possible power, Magtrol AHB Series Hysteresis Brakes are ideal. Passages running through the brakes enables compressed air cooling, providing excellent heat dissipation. Allowable input air pressure of up to 95 PSI eliminates the need for a regulator and convenient base mounting enables easy configuration.

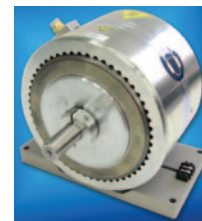

RATINGS (Available in Metric Only)									
Model	Min. Torque at Rated Current N-m	Rated Current mA	Voltage VDC	Nominal Power W	Max. Speed rpm	Kinetic Power *			
						With Air		Without Air	
						5 Minutes W	Continuous W	5 Minutes W	Continuous W
AHB-1	1.00	400	24.0	9.6	25,000	1200	1200	250	55
AHB-1.75	1.75	270	22.4	9.0	25,000	1000	600	450	110
AHB-3	3.00	750	24.8	18.6	20,000	1800	1800	800	160
AHB-5	5.00	380	22.8	8.7	15,000	2500	1000	1300	120
AHB-6	6.00	1500	24.8	37.1	20,000	3000	3000	1400	225
AHB-12	12.00	1200	24.0	28.8	12,000	2800	1800	2200	250
AHB-24	24.00	2400	24.0	57.6	12,000	5300	3000	4000	450

\* Kinetic power ratings are maximum values based on limiting coil and/or bearing temperature to approximately 100 °C, and should not be exceeded.

# MATCHED BRAKES

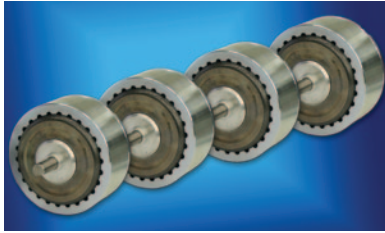

In tension control applications that have multiple webs or multiple strands it is very desirable to match the tension of each web or strand. This is most commonly attained by using a closed loop servo control system which controls current to a braking device through the use of dancer arms, follower arms and in-line tension transducers. The problem with such systems is that each web or strand must be individually controlled, increasing the cost and complicating the system with multiple sensors and power supplies.

Magtrol has developed a system to assure that every brake of a given model designation will be matched, at a predetermined torque and current point, to other brakes of the same model designation regardless of material and manufacturing tolerances. Each brake will be matched at the selected match point to within a tolerance of  $\pm 1\%$ . The maximum deviation in torque from brake to brake at any point along their torque/current curve (from 0 torque up to the selected matched torque point) will be less than  $\pm 4\%$  of the selected matched torque value. With this level of matching, a system with multiple tension rollers would provide tension consistency within  $\pm 1\%$  if set at the matched point with all brakes receiving the same current. The matched point can be any value between 50% and 100% of rated torque, which allows the brakes to be optimized for specific applications. Unless otherwise specified, all brakes are matched at 100 rpm.

ENGLISH BRAKE RATINGS										
Model	Min. Torque at Rated Current	Rated Current	Resistance at 25 °C $\pm 10\%$	Voltage*	Nominal Power	Max. Speed	Kinetic Power**		Drag Torque De-energized @1000 rpm	
	oz-in	mA	$\Omega$	VDC	W	rpm	5 Minutes W	Continuous W	oz-in	
MHB-2.5-2	2.5	98	262	25.0	3.7	20,000	20	7	0.05	
MHB-10.5-2	11	201	113	24.0	3.2	20,000	60	15	0.10	
MHB-38-2	38	250	105	26.3	6.6	15,000	90	25	0.20	
MHB-50-2	50	253	95	24.0	6.1	15,000	90	23	0.20	
MHB-140-2	140	253	95	24.0	6.1	12,000	300	75	0.70	
MHB-250-2	250	270	96	25.9	7.0	10,000	450	110	1.00	
MHB-450-2	450	442	50	22.1	9.8	8,000	670	160	2.00	
MHB-750-2	750	383	60	23.0	8.8	7,000	1,000	200	7.00	
MHB-1750-2	1750	500	52	26.0	13.0	6,000	1,200	350	13.00	

\* 12 VDC, 90 VDC and non-standard coil voltages are available on most models.

\*\* Kinetic power ratings are maximum values based on limiting coil and/or bearing temperature to approximately 100 °C, and should not be exceeded. Actual values in service may vary  $\pm 50\%$  depending on mounting, ventilation, ambient temperature, etc.

METRIC BRAKE RATINGS										
All standard metric brakes are also available in matched brake configurations, with the exception of the HB-3500M Series. Technical data for these brakes is identical to that of its standard counterpart. For example, the MHB-140M-2 has the same ratings as the HB-140M-2.										

# HYSTERESIS CLUTCHES

Like Magtrol's Hysteresis Brake, the Hysteresis Clutch develops torque strictly through a magnetic air gap, ensuring an absolutely smooth transmission of torque from the drive unit to the driven element. Designed to be powered without the use of brushes or slip rings, and being a pure hysteresis device, there is never any fear of contamination due to wear particles or leaky seals. This makes Magtrol Hysteresis Clutches and Brakes ideal for use in food processing and clean room environments.



RATINGS (Available in Metric Only)										
Model	Min. Torque at Rated Current	Rated Current	Resistance at 25 °C $\pm 10\%$	Voltage*	Nominal Power	Max. Speed	Kinetic Power**		Inertia	
	N-m	mA	$\Omega$	VDC	W	rpm	5 Minutes W	Continuous W	Input Shaft kg-cm <sup>2</sup>	Output Shaft kg-cm <sup>2</sup>
HCF-8M	0.0565	150	180.0	27.0	4.05	3600	60	15	0.299	0.038
HCF-16M	0.113	270	100.0	27.0	7.29	3600	75	20	0.543	0.041
HCF-32M	0.226	332	72.5	24.0	7.99	3600	90	25	0.984	0.089
HCF-120M	0.850	200	120.0	24.0	4.80	3600	300	75	9.490	0.910
HCF-250M	1.800	415	60.0	24.9	10.30	3600	450	110	25.560	2.760

\* 12 VDC, 90 VDC and non-standard coil voltages are available on all models.

\*\* Kinetic power ratings are maximum values based on limiting coil and/or bearing temperature to approximately 100 °C, and should not be exceeded. Actual values in service may vary  $\pm 50\%$  depending on mounting, ventilation, ambient temperature, etc.

# LARGE BORE BRAKES

For many years Magtrol has designed Hysteresis Brakes with large bores, and without a shaft or bearings. These brakes are used for superior tension control for helical wrapping, braiding and other feed through applications in machines used for manufacturing cable, wire, fiber optic cable, rope and tape, among others. Magtrol Large Bore Brakes provide smooth, repeatable torque, largely independent of speed.



These brakes consist of two primary parts: a pole/case assembly and a rotor. The pole/case assembly is usually mounted in a stationary position within the machine, while the rotor is shaft mounted concentrically within the pole/case assembly.

The pole/case assembly and rotor are manufactured in standard bore sizes and hole patterns. Variations to the standard dimensions can be made based on customer requirements. Certain modifications to the brake, such as a larger bore dimension, may impact its performance ratings.

Additional options available include rotor mounting flanges, power supplies, torque-current curves and other coil voltages. Contact Magtrol for more information.

RATINGS (Available in Metric Only)								
Model	Min. Torque at Rated Current	Rated Current	Resistance at 25 °C ±10%	Voltage*	Nominal Power	Max. Speed	Kinetic Power**	
							5 Minutes	Continuous
	oz-in	mA	Ω	VDC	W	rpm	W	W
LB-250M-2	1.50	270	95	25.6	6.99	3000	450	110
LB-450M-2	3.00	442	50	22.1	9.80	2500	670	160
LB-750M-2	5.00	383	60	23.0	8.82	2000	1000	200
LB-1750M-2	12.00	500	52	26.0	13.00	1800	1200	350

\* Higher speeds, up to 8000 rpm, are available on special basis.

\*\* Kinetic power ratings are maximum values based on limiting coil and/or bearing temperature to approximately 100 °C, and should not be exceeded. Actual values in service may vary ±50% depending on mounting, ventilation, ambient temperature, etc.

# PERMANENT MAGNET BRAKES & CLUTCHES

Magtrol Hysteresis Permanent Magnet Brakes and Clutches are ideal in applications where electrical power cannot be provided to a brake or clutch coil. While best suited to applications where fixed torque is to be applied, adjustable units can be made specifically tailored to the application. Typically provided as brake units, with the addition of an input shaft, the same unit can be used as a clutch. In a clutch application, the pole/case member becomes the drive element, and the rotor/shaft assembly becomes the driven element of the clutch with torque being transmitted through the magnetic air-gap. Magtrol Hysteresis Permanent Magnet devices provide all the superior operating characteristics of smooth operation, precise repeatability and long life inherent in our standard Hysteresis Brakes and Clutches.



RATINGS (Available in English Only)					
Brake Model	Clutch Model	Rated Torque*	Maximum Speed**	Kinetic Power	
				5 Minutes	Continuous
		oz-in	rpm	W	W
HPM-2.5	HPMC-2.5	2.5	10,820	20	7
HPM-8	HPMC-8	8	10,140	60	15
HPM-16	HPMC-16	16	6,340	75	20
HPM-32	HPMC-32	32	3,800	90	25
HPM-120	HPMC-120	120	3,380	300	75
HPM-210	HPMC-210	210	2,900	450	110

\* Permanent Magnet Brakes can be charged at factory to produce lower torque if desired.

\*\* Maximum speed listed will produce 5-minute kinetic power rating at rated torque.

Complete technical specifications for most of the products described in this brochure, including detailed dimension drawings, are available on our web site:

[www.magtrol.com](http://www.magtrol.com)

3-D model and/or installation drawings are available upon request.

# OPTIONS & ACCESSORIES

Since 1953, Magtrol has created literally thousands of special and modified brake designs to help solve specific application problems for our customers.

## Common Modifications

- Non-standard Coil Voltages
- Special Shaft Configurations: keyways, flats, holes and hollow
- Dust Covers
- Speed Pickups
- Special Mounting Configurations
- Non-standard Leads
- Blower-cooled Designs
- Higher Torque Devices
- High-speed Units

## Higher Torque Capability

It is Magtrol's policy never to overstate the capabilities of our products. As a result, our brakes are conservatively rated. Higher torque values (15-25% above rated torque) are typically available from each brake, depending on the brake being ordered. In addition, special designs capable of producing even higher torques are available.

## Brake Options

Base Mounting • Torque Current Curves • Pillow Blocks

## Power Supplies

For optimum torque stability, Magtrol offers four different power supplies for its Hysteresis Brakes and Clutches:

### MODEL 5200 POWER SUPPLY

Model 5200 is an unregulated 0–35 VDC Power Supply which offers control and regulation of the braking torque via a 10-turn potentiometer. The 5200 is our most basic control for manual testing in an open loop torque control mode.



Model 5210 Power Supply

### MODEL 5210 CURRENT REGULATED POWER SUPPLY

Model 5210 provides the same control capabilities as the 5200, and also provides current regulation of the brake. With regulated current, the 5210 will eliminate torque drift caused by temperature changes within the brake coil.

### MODEL 5250 CURRENT REGULATED POWER SUPPLY

Model 5250-2 is an open frame, current regulated power supply that provides smooth application of current from zero to maximum by either a 10-turn 5 k $\Omega$  potentiometer, or by an external 0–5 VDC control signal.

## MAGTROL INC

70 Gardenville Parkway  
Buffalo, New York 14224 USA  
Phone: +1 716 668 5555  
Fax: +1 716 668 8705  
E-mail: magtrol@magtrol.com

## MAGTROL SA

Route de Montena 77  
1728 Rossens/Fribourg, Switzerland  
Phone: +41 (0)26 407 3000  
Fax: +41 (0)26 407 3001  
E-mail: magtrol@magtrol.ch

Subsidiaries in:  
Germany • France • U.K.  
China • India

For worldwide network of sales agents, visit our web site:

[www.magtrol.com](http://www.magtrol.com)

*Due to the continual development of our products, we reserve the right to modify specifications without forewarning.*

For more information, contact your local sales agent:

HB-US www 02/10

